

LMC660

CMOS Quad Operational Amplifier

General Description

The LMC660 CMOS Quad operational amplifier is ideal for operation from a single supply. It operates from +5V to +15.5V and features rail-to-rail output swing in addition to an input common-mode range that includes ground. Performance limitations that have plagued CMOS amplifiers in the past are not a problem with this design. Input V_{OS} , drift, and broadband noise as well as voltage gain into realistic loads (2 k Ω and 600 Ω) are all equal to or better than widely accepted bipolar equivalents.

This chip is built with National's advanced Double-Poly Silicon-Gate CMOS process.

See the LMC662 datasheet for a dual CMOS operational amplifier with these same features.

Features

- Rail-to-rail output swing
- Specified for 2 k Ω and 600 Ω loads
- High voltage gain: 126 dB

- Low input offset voltage: 3 mV
- Low offset voltage drift: 1.3 $\mu\text{V}/^\circ\text{C}$
- Ultra low input bias current: 2 fA
- Input common-mode range includes V^-
- Operating range from +5V to +15.5V supply
- $I_{SS} = 375 \mu\text{A}/\text{amplifier}$; independent of V^+
- Low distortion: 0.01% at 10 kHz
- Slew rate: 1.1 V/ μs

Applications

- High-impedance buffer or preamplifier
- Precision current-to-voltage converter
- Long-term integrator
- Sample-and-Hold circuit
- Peak detector
- Medical instrumentation
- Industrial controls
- Automotive sensors

Connection Diagram

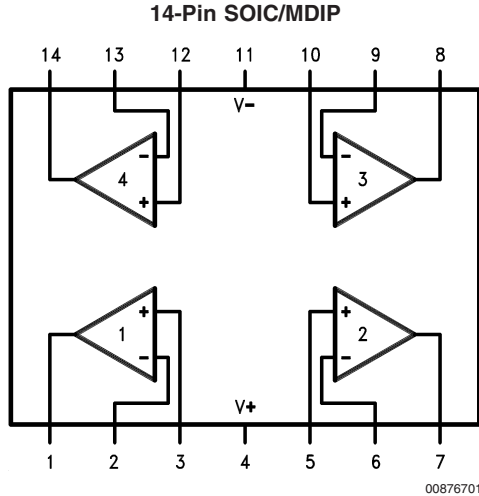

LMC660 Circuit Topology (Each Amplifier)

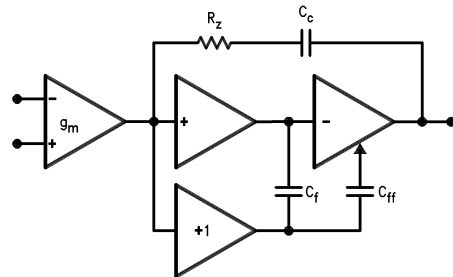

00876704

Absolute Maximum Ratings (Note 3)

If Military/Aerospace specified devices are required, please contact the National Semiconductor Sales Office/Distributors for availability and specifications.

Differential Input Voltage	±Supply Voltage
Supply Voltage	16V
Output Short Circuit to V ⁺	(Note 11)
Output Short Circuit to V ⁻	(Note 1)
Lead Temperature (Soldering, 10 sec.)	260°C
Storage Temp. Range	-65°C to +150°C
Voltage at Input/Output Pins	(V ⁺) + 0.3V, (V ⁻) - 0.3V
Current at Output Pin	±18 mA
Current at Input Pin	±5 mA
Current at Power Supply Pin	35 mA

Power Dissipation	(Note 2)
Junction Temperature	150°C
ESD tolerance (Note 8)	1000V

Operating Ratings

Temperature Range	
LMC660AI	-40°C ≤ T _J ≤ +85°C
LMC660C	0°C ≤ T _J ≤ +70°C
Supply Voltage Range	4.75V to 15.5V
Power Dissipation	(Note 9)
Thermal Resistance (θ _{JA}) (Note 10)	
14-Pin SOIC	115°C/W
14-Pin MDIP	85°C/W

DC Electrical Characteristics

Unless otherwise specified, all limits guaranteed for T_J = 25°C. **Boldface** limits apply at the temperature extremes. V⁺ = 5V, V⁻ = 0V, V_{CM} = 1.5V, V_O = 2.5V and R_L > 1MΩ unless otherwise specified.

Parameter	Conditions	Typ (Note 4)	LMC660AI	LMC660C	Units	
			Limit (Note 4)	Limit (Note 4)		
Input Offset Voltage		1	3 3.3	6 6.3	mV max	
Input Offset Voltage Average Drift		1.3			μV/°C	
Input Bias Current		0.002	4	2	pA max	
Input Offset Current		0.001	2	1	pA max	
Input Resistance		>1			TeraΩ	
Common Mode Rejection Ratio	0V ≤ V _{CM} ≤ 12.0V V ⁺ = 15V	83	70 68	63 62	dB min	
Positive Power Supply Rejection Ratio	5V ≤ V ⁺ ≤ 15V V _O = 2.5V	83	70 68	63 62	dB min	
Negative Power Supply Rejection Ratio	0V ≤ V ⁻ ≤ -10V	94	84 83	74 73	dB min	
Input Common-Mode Voltage Range	V ⁺ = 5V & 15V For CMRR ≥ 50 dB	-0.4	-0.1 0	-0.1 0	V max	
		V ⁺ - 1.9	V ⁺ - 2.3 V⁺ - 2.5	V ⁺ - 2.3 V⁺ - 2.4	V min	
Large Signal Voltage Gain	R _L = 2 kΩ (Note 5)	Sourcing	2000	440 400	300 200	V/mV min
		Sinking	500	180 120	90 80	V/mV min
	R _L = 600Ω (Note 5)	Sourcing	1000	220 200	150 100	V/mV min
		Sinking	250	100 60	50 40	V/mV min

DC Electrical Characteristics (Continued)

Unless otherwise specified, all limits guaranteed for $T_J = 25^\circ\text{C}$. **Boldface** limits apply at the temperature extremes. $V^+ = 5\text{V}$, $V^- = 0\text{V}$, $V_{\text{CM}} = 1.5\text{V}$, $V_O = 2.5\text{V}$ and $R_L > 1\text{M}\Omega$ unless otherwise specified.

Parameter	Conditions	Typ (Note 4)	LMC660AI	LMC660C	Units	
			Limit (Note 4)	Limit (Note 4)		
Output Swing	$V^+ = 5\text{V}$ $R_L = 2\text{ k}\Omega$ to $V^+/2$	4.87	4.82 4.79	4.78 4.76	V min	
		0.10	0.15 0.17	0.19 0.21	V max	
	$V^+ = 5\text{V}$ $R_L = 600\Omega$ to $V^+/2$	4.61	4.41 4.31	4.27 4.21	V min	
		0.30	0.50 0.56	0.63 0.69	V max	
	$V^+ = 15\text{V}$ $R_L = 2\text{ k}\Omega$ to $V^+/2$	14.63	14.50 14.44	14.37 14.32	V min	
		0.26	0.35 0.40	0.44 0.48	V max	
	$V^+ = 15\text{V}$ $R_L = 600\Omega$ to $V^+/2$	13.90	13.35 13.15	12.92 12.76	V min	
		0.79	1.16 1.32	1.45 1.58	V max	
	Output Current $V^+ = 5\text{V}$	Sourcing, $V_O = 0\text{V}$	22	16 14	13 11	mA min
		Sinking, $V_O = 5\text{V}$	21	16 14	13 11	mA min
	Output Current $V^+ = 15\text{V}$	Sourcing, $V_O = 0\text{V}$	40	28 25	23 21	mA min
		Sinking, $V_O = 13\text{V}$ (Note 11)	39	28 24	23 20	mA min
Supply Current	All Four Amplifiers $V_O = 1.5\text{V}$	1.5	2.2 2.6	2.7 2.9	mA max	

AC Electrical Characteristics

Unless otherwise specified, all limits guaranteed for $T_J = 25^\circ\text{C}$. **Boldface** limits apply at the temperature extremes. $V^+ = 5\text{V}$, $V^- = 0\text{V}$, $V_{\text{CM}} = 1.5\text{V}$, $V_O = 2.5\text{V}$ and $R_L > 1\text{M}\Omega$ unless otherwise specified.

Parameter	Conditions	Typ (Note 4)	LMC660AI	LMC660C	Units
			Limit (Note 4)	Limit (Note 4)	
Slew Rate	(Note 6)	1.1	0.8 0.6	0.8 0.7	V/ μs min
Gain-Bandwidth Product		1.4			MHz
Phase Margin		50			Deg
Gain Margin		17			dB
Amp-to-Amp Isolation	(Note 7)	130			dB
Input Referred Voltage Noise	$F = 1\text{ kHz}$	22			$\text{nV}/\sqrt{\text{Hz}}$
Input Referred Current Noise	$f = 1\text{ kHz}$	0.0002			$\text{pA}/\sqrt{\text{Hz}}$

AC Electrical Characteristics (Continued)

Unless otherwise specified, all limits guaranteed for $T_J = 25^\circ\text{C}$. **Boldface** limits apply at the temperature extremes. $V^+ = 5\text{V}$, $V^- = 0\text{V}$, $V_{\text{CM}} = 1.5\text{V}$, $V_O = 2.5\text{V}$ and $R_L > 1\text{M}\Omega$ unless otherwise specified.

Parameter	Conditions	Typ (Note 4)	LMC660AI	LMC660C	Units
			Limit (Note 4)	Limit (Note 4)	
Total Harmonic Distortion	$f = 10\text{ kHz}$, $A_V = -10$ $R_L = 2\text{ k}\Omega$, $V_O = 8\text{ V}_{\text{PP}}$ $V^+ = 15\text{V}$	0.01			%

Note 1: Applies to both single supply and split supply operation. Continuous short circuit operation at elevated ambient temperature and/or multiple Op Amp shorts can result in exceeding the maximum allowed junction temperature of 150°C . Output currents in excess of $\pm 30\text{ mA}$ over long term may adversely affect reliability.

Note 2: The maximum power dissipation is a function of $T_{\text{J(MAX)}}$, θ_{JA} , and T_A . The maximum allowable power dissipation at any ambient temperature is $P_D = (T_{\text{J(MAX)}} - T_A)/\theta_{\text{JA}}$.

Note 3: Absolute Maximum Ratings indicate limits beyond which damage to the device may occur. Operating Ratings indicate conditions for which the device is intended to be functional, but do not guarantee specific performance limits. For guaranteed specifications and test conditions, see the Electrical Characteristics. The guaranteed specifications apply only for the test conditions listed.

Note 4: Typical values represent the most likely parametric norm. Limits are guaranteed by testing or correlation.

Note 5: $V^+ = 15\text{V}$, $V_{\text{CM}} = 7.5\text{V}$ and R_L connected to 7.5V . For Sourcing tests, $7.5\text{V} \leq V_O \leq 11.5\text{V}$. For Sinking tests, $2.5\text{V} \leq V_O \leq 7.5\text{V}$.

Note 6: $V^+ = 15\text{V}$. Connected as Voltage Follower with 10V step input. Number specified is the slower of the positive and negative slew rates.

Note 7: Input referred. $V^+ = 15\text{V}$ and $R_L = 10\text{ k}\Omega$ connected to $V^+/2$. Each amp excited in turn with 1 kHz to produce $V_O = 13\text{ V}_{\text{PP}}$.

Note 8: Human Body Model is $1.5\text{ k}\Omega$ in series with 100 pF .

Note 9: For operating at elevated temperatures the device must be derated based on the thermal resistance θ_{JA} with $P_D = (T_J - T_A)/\theta_{\text{JA}}$.

Note 10: All numbers apply for packages soldered directly into a PC board.

Note 11: Do not connect output to V^+ when V^+ is greater than 13V or reliability may be adversely affected.

Ordering Information

Package	Temperature Range		Transport Media	NSC Drawing
	Industrial -40°C to $+85^\circ\text{C}$	Commercial 0°C to $+70^\circ\text{C}$		
14-Pin SOIC	LMC660AIM	LMC660CM	Rail	M14A
	LMC660AIMX	LMC660CMX	Tape and Reel	
14-Pin M DIP	LMC660AIN	LMC660CN	Rail	N14A

Physical Dimensions inches (millimeters) unless otherwise noted

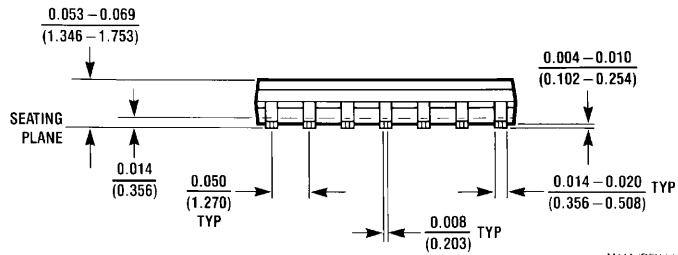
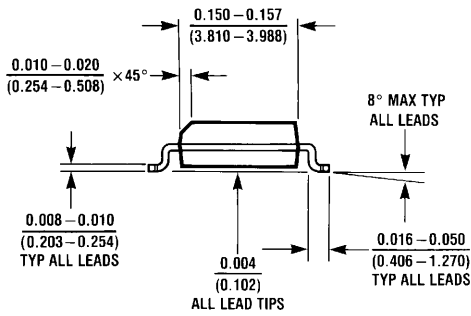
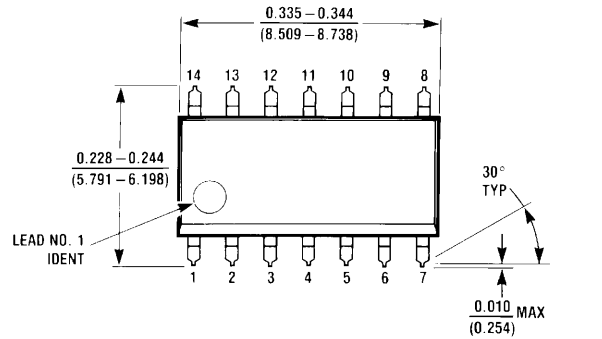

M14A (REV H)

14-Pin SOIC
NS Package Number M14A

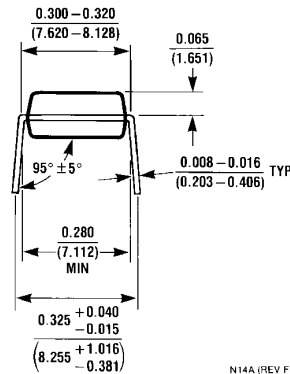
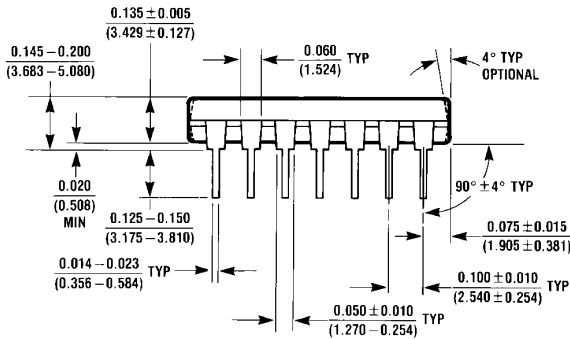
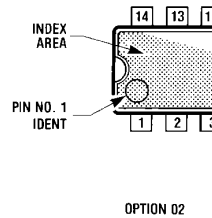
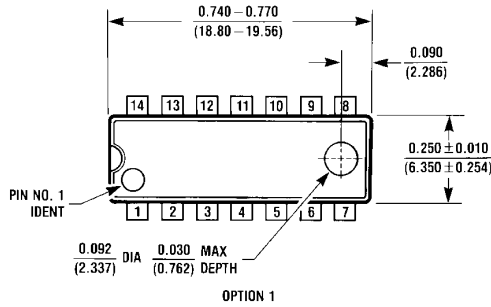

N14A (REV F)

14-Pin MDIP
NS Package Number N14A